

Check Pen S

CP-##SX

Instruction Manual V1.10

Please use this Instruction manual correctly on reading well.
Please keep it carefully to be able to read immediately, when required.

Table of Contents

■ Overview	1
■ Main Body and Accessories	2
■ Safety Precautions (Be Sure to Read This) ...	5
■ Name and Function of Each Part	9
■ How to Install	11
■ Setting	13
■ How to Use the Check Pen S	14
■ Specifications	16
■ Dimensions Drawing	17
■ Before Determining Fault	20
■ After Service and Warranty	21

■ Overview

“Check Pen S” is a pokayoke (mistake prevention) tool with a compact wireless module HRF-2402 built in for transmitting work confirmation to prevent mistakes in marking and approval marking.

The Check Pen S can communicate with a Pokayoke receiver “TW-800R-***” series.

<Features>

- ◆Compatible with various brands of pens by changing the barrel of the Check Pen S.
- ◆We support commercially available stamps.
- ◆Reliable communication
 - TW-800 can communicate automatically by selecting the channel from 76ch in 2.4GHz bandwidth.
 - TW-800 transmits the signal reliably by 2way communication. (You can look see the communication OK/NG by LED lighting and flashing.)
- ◆Uses a small and lightweight coin battery as a power source.
- ◆Battery life of about 300,000 uses. (depending on usage conditions)
- ◆Battery level notification function
 - A function to notify when the battery level is low (when press with test switch) or when the battery needs to be replaced.
 - The battery level will be notified by both Check Pen S and receiver LEDs when the battery level is low and will be notified by Check Pen S LED when the battery needs to be replaced.
- ◆Uses a communication band that is available worldwide.
- ◆The Check Pen S can communicate with a receiver TW-800R-***.
- ◆Communication distance of approx.30m indoors (varies depending on the operating environment).
- ◆Available countries : Japan, Canada, USA, China, Thailand, Vietnam, Philippines, Indonesia and India.

■Main Body and Accessories

Check Pen S CP-##SX (When using the Main Body Unit CP-SX)

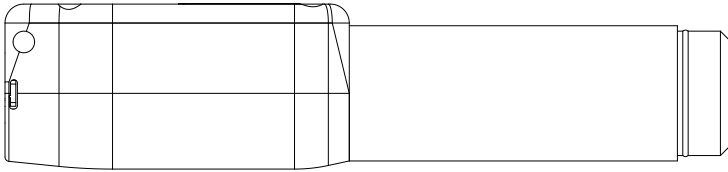

CP-##SX Main body x 1
(Wireless module built in HRF-2402)

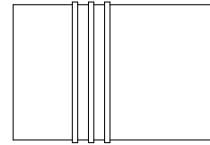

Barrel x 1
(CP-##S-PP)

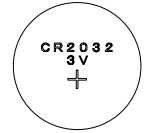

Pen-Cap x 1
(CP-S-CA)

Coin battery CR2032 x 1

*Pen-Caps are included with the CP-02SX,CP-11SX,and CP-26SX,but not included with other models.

*The pen and stamp are not included.

*The Check Pen S is delivered with a coin battery installed.

Check Pen S CP-##SX (When using the Main Body Unit CP-SLX)

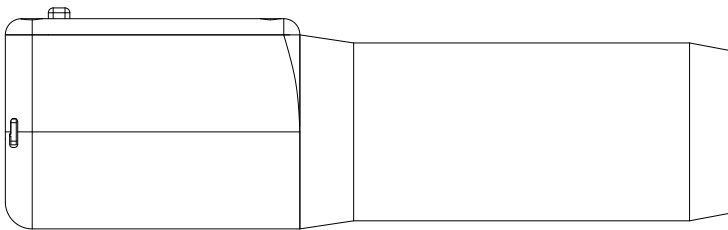

CP-##SX Main body x 1
(Wireless module built in HRF-2402)

Barrel x 1
(CP-##S-PP)

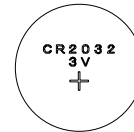

Coin battery CR2032 x 1

*The cap is not included because it uses a genuine pen and stamp cap.

*The pen and stamp are not included.

*The Check Pen S is delivered with a coin battery installed.

Check Pen S compatible list

Model	Type	Part Number	Manufactures	Main Body Unit	Barrel	Pen/'Self-Inking Stamp' Cap
CP-02SX	Pen	PX-20 M-20PM MMP-20	Mitsubishi Pencil Pilot Corporation Pentel	CP-SX	CP-02S-PP	CP-S-CA
CP-05SX	Pen	PX-21	Mitsubishi Pencil	CP-SX	CP-05S-PP	Please use the originally supplied pen cap.
CP-09SX	Pen	H-DM	Tombow	CP-SX	CP-09S-PP	-
CP-11SX	Pen	K-177N	Shachihata	CP-SX	CP-11S-PP	CP-S-CA
CP-26SX	Self-Inking Stamp	X-BKL	Shachihata	CP-SX	CP-26S-PP	CP-S-CA
CP-70SX	Pen	Skill Writer II	Shinwa	CP-SLX	CP-70S-PP	Please use the originally supplied pen cap.
CP-71SX	Self-Inking Stamp	TAT Stamper F11 XQT-11C	Shachihata	CP-SLX	CP-71S-PP	Please use the originally supplied self-inking stamp cap.
CP-72SX	Pen	Steel Paint NEO	Alton	CP-SLX	CP-72S-PP	Please use the originally supplied pen cap.
CP-81SX	Self-Inking Stamp	Name Stamp XL-11	Shachihata	CP-SLX	CP-81S-PP	Please use the originally supplied self-inking stamp cap.

*Pens and self-inking stamps not on the list are also supported. Please contact us.

Options

▪ Main Body Unit **CP-SX**

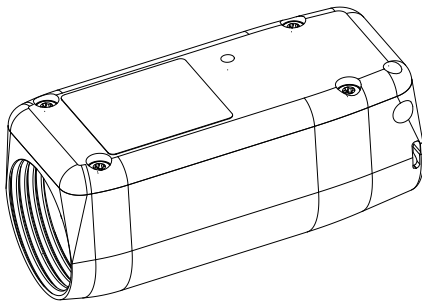

▪ Main Body Unit **CP-SLX**

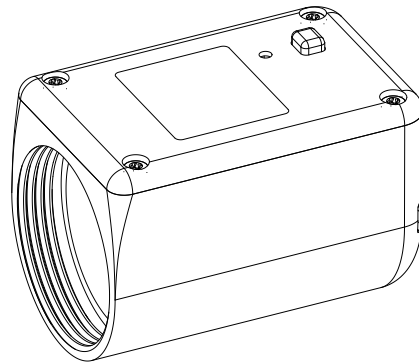

▪ Pen-Cap **CP-S-CA (Common)**

Used with CP-02X, CP-11SX, and CP-26SX.

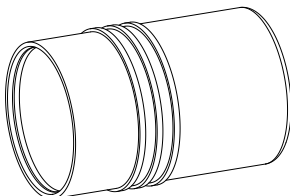

▪ Battery Cap **CP-SX-B01(Common)**

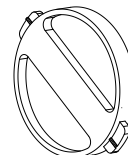

▪ **Barrel CP-##S-PP**

The number of the ## part of the model changes depending on the pen and stamp.
 All barrels listed in the check pen S compatible list are optional.
 The following models have accessories other than barrels.

CP-70S-PP (For Skill Writer)

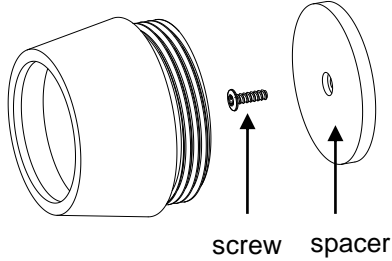

CP-26S-PP (For X-BKL)

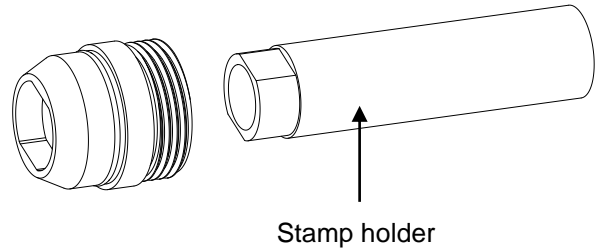

▪ **Switch board CP-SX-SWBT**

This is a switch board dedicated to the main body unit CP-SX.
 * Cannot be used for CP-S, CP-SL, and CP-SLX.

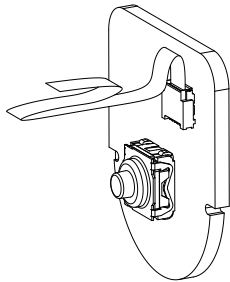

▪ **Switch board CP-SLX-SWBT**

This is a switch board dedicated to the main body unit CP-SLX.
 * Cannot be used for CP-S, CP-SL, and CP-SX.

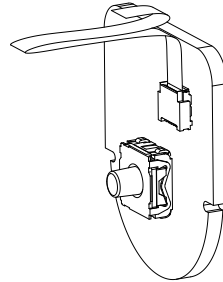

* The switch board comes with a preformed flat cable.

▪ **Strap CP-SXT**

Only the main body unit CP-SX can be used.

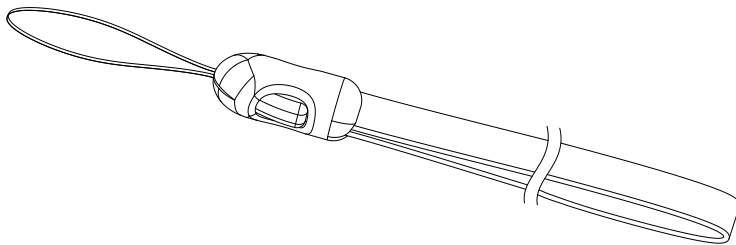

■ Safety Precautions (Be Sure to Read This)

This section describes the matters to be observed in order to prevent harm to the users and other persons and damages to the property.

■ The following marks and displays classify and describe the extent of harm and damage caused by failing to observe the display content and using this product wrongly.

	Caution	This display column shows "a failure to do observe it could result in only the personal injury or property damage".
---	----------------	---

■ Handling this product



<ul style="list-style-type: none"> ● This product is the wireless communication equipment made of precision parts. Do not disassemble or modify it. Or the accident or fault may occur. 	
--	---

■ Use and storage environment

<ul style="list-style-type: none"> ● DO NOT USE OR STORE the product in the following places to prevent defects, malfunction, deterioration, fire, and electric shock: <ul style="list-style-type: none"> · Do not use and store it in places exposed to direct sunlight, · Do not use and store it in places where liquids, foreign substances, corrosive gases or combustible gases can enter the product, · Do not use and store it in places with high humidity or where there is abundant oil smoke, dust, sand, etc. , · Do not use it in an unstable place such as a wobbling table or an inclined plane, · Do not use it in a place with vibration. 	
--	---



■ Specific handling of this product

This product is a radio equipment with certification of construction design.

<ul style="list-style-type: none"> ● It is prohibited by law to disassemble or modify certified devices. 	
<ul style="list-style-type: none"> ● Do not remove the certification label affixed to the case. It is prohibited to use any product without the label. 	
<ul style="list-style-type: none"> ● This product is only available in the countries where the certification is acquired. 	

	Warning	This display column shows "a failure to do observe it could result in death or serious personal injury".
---	----------------	--

■ Handling this product

<ul style="list-style-type: none"> ● Do not use this product for application that requires the extremely high reliability affecting the human life. 	
<ul style="list-style-type: none"> ● Do not use this product in the area which the radio wave reaches or not. 	

■ If a problem occurs during use

<ul style="list-style-type: none"> ● When smoke comes or there is a strange smell, immediately stop usage and remove the power plug from the outlet because it may cause fire and electric shock. Request the dealer or our company to repair it. 	
--	---

■Notes on the Radio Law

○The wireless device used for this product is certified as a specific radio device for a radio equipment of a low power data communication system based on the Radio Law. Therefore, a radio station license is not required to use this product.

○This product can be used only in Japan or countries where required certification is acquired. In the case that it is used in other countries, this product may be damaged or it may damage other equipment. It also may conflict with the laws of that country. Please contact our sales department for the countries that the product is certified other than Japan.

○Do not use this product near any person using cardiac pacemaker. The cardiac pacemaker may be disturbed by electromagnetic wave, which may cause risk of life.

○Do not use this product near any medical equipment. The medical equipment may be disturbed by electromagnetic wave, which may cause risk of life.

○Do not use this product near any microwave oven. Electromagnetic wave from microwave oven may disturb radio communication.

○The wireless device of this product is certified under the Radio Law, so that DO NOT disassemble or remodel this product.

■Notes on radio interference of 2.4 GHz radio

When communicating with 2.4 GHz band wireless products, pay attention to the following points.

In this product's frequency band not only industrial, scientific and medical equipment such as microwave ovens but also local radio stations for mobile objects identification (which require the license), specified low-power radio stations (license not required), and amateur radio stations (license required) can be in operation.

○Before using this product, make sure that there are no local radio stations for mobile objects identification, specified low-power radio stations and amateur radio stations operating nearby.

○In event that harmful interference occurs to any radio station by the radio wave from this product, stop using it immediately and consult with us about avoiding interference.

○Also contact us in case of any trouble such as harmful radio interference to specified low-power radio stations for mobile objects identification or amateur radio stations.

"Check Pen S" is equipped with the built-in wireless module HRF-2402.

Available countries : Japan, Canada, USA, China, Thailand, Vietnam, Philippines, Indonesia and India.

■ FCC/IC Warning

Information about FCC Standard.

FCC CAUTION

Change or modifications not expressly approved by the party responsible for compliance could void the user's authority to operate the equipment.

This transmitter must not be co-located or operated in conjunction with any other antenna or transmitter.

This equipment complies with FCC radiation exposure limits set forth for an uncontrolled environment and meets the FCC radio frequency (RF) Exposure Guidelines. This equipment has very low levels of RF energy that is deemed to comply without maximum permissive exposure evaluation (MPE).

This equipment complies with FCC radiation exposure limits set forth for an uncontrolled environment and meets the FCC radio frequency (RF) Exposure Guidelines. This equipment has very low levels of RF energy that is deemed to comply without testing of specific absorption rate(SAR).

I Information about ISED Standard.

This device complies with Industry Canada's applicable license-exempt RSSs. Operation is subject to the following two conditions:

- (1) This device may not cause interference; and
- (2) This device must accept any interference, including interference that may cause undesired operation of the device.

Le présent appareil est conforme aux CNR d'Industrie Canada applicables aux appareils radio exempts de licence. L'exploitation est autorisée aux deux conditions suivantes :

- 1) l'appareil ne doit pas produire de brouillage;
- 2) l'utilisateur de l'appareil doit accepter tout brouillage radioélectrique subi, même si le brouillage est susceptible d'en compromettre le fonctionnement.

This equipment complies with IC radiation exposure limits set forth for an uncontrolled environment and meets RSS-102 of the IC radio frequency (RF) Exposure rules. This equipment has very low levels of RF energy that is deemed to comply without maximum permissive exposure evaluation (MPE).

Cet équipement est conforme aux limites d'exposition aux rayonnements énoncées pour un environnement non contrôlé et respecte les règles d'exposition aux fréquences radioélectriques (RF) CNR-102 de l'IC. Cet équipement émet une énergie RF très faible qui est considérée comme conforme sans évaluation de l'exposition maximale autorisée (MPE).

This equipment complies with IC radiation exposure limits set forth for an uncontrolled environment and meets RSS-102 of the IC radio frequency (RF) Exposure rules. This equipment has very low levels of RF energy that is deemed to comply without testing of specific absorption rate (SAR).

Cet équipement est conforme aux limites d'exposition aux rayonnements énoncées pour un environnement non contrôlé et respecte les règles d'exposition aux fréquences radioélectriques (RF) CNR-102 de l'IC. Cet équipement émet une énergie RF très faible qui est considérée comme conforme sans évaluation du débit d'absorption spécifique (DAS).

This radio transmitter (10608A-HRF2402) identify the device by certification number or model number if Category II) has been approved by Industry Canada to operate with the antenna types listed below with the maximum permissible gain indicated. Antenna types not included in this list, having a gain greater than the maximum gain indicated for that type, are strictly prohibited for use with this device.

Antenna type: 1/4λ Dipole antenna (chip antenna) Gain: 3dBi

Antenna type: 1/2λ Dipole antenna Gain: 2dBi

Antenna type: 1/2λ Dipole antenna Magnet Base Gain: 2dBi

Le présent émetteur radio (10608A-HRF2402) a été approuvé par Industrie Canada pour fonctionner avec les types d'antenne énumérés ci-dessous et ayant un gain admissible maximal. Les types d'antenne non inclus dans cette liste, et dont le gain est supérieur au gain maximal indiqué, sont strictement interdits pour l'exploitation de l'émetteur.

Type d'antenne: 1/4λ Dipole antenna (chip antenna) Gain: 3dBi

Type d'antenne: 1/2λ Dipole antenna Gain: 2dBi

Type d'antenne: 1/2λ Dipole antenna Magnet Base Gain: 2dBi

■ Thailand Radio Law (SDoC)

This telecommunication equipment is in compliance with NBTC requirements.

■ Information about SDPPI(Indonesia)

CP-SX

85665/SDPPI/2022
3441

■Name and Function of Each Part

Check Pen S CP-##SX (When using the Main Body Unit CP-SX)

[Pens]

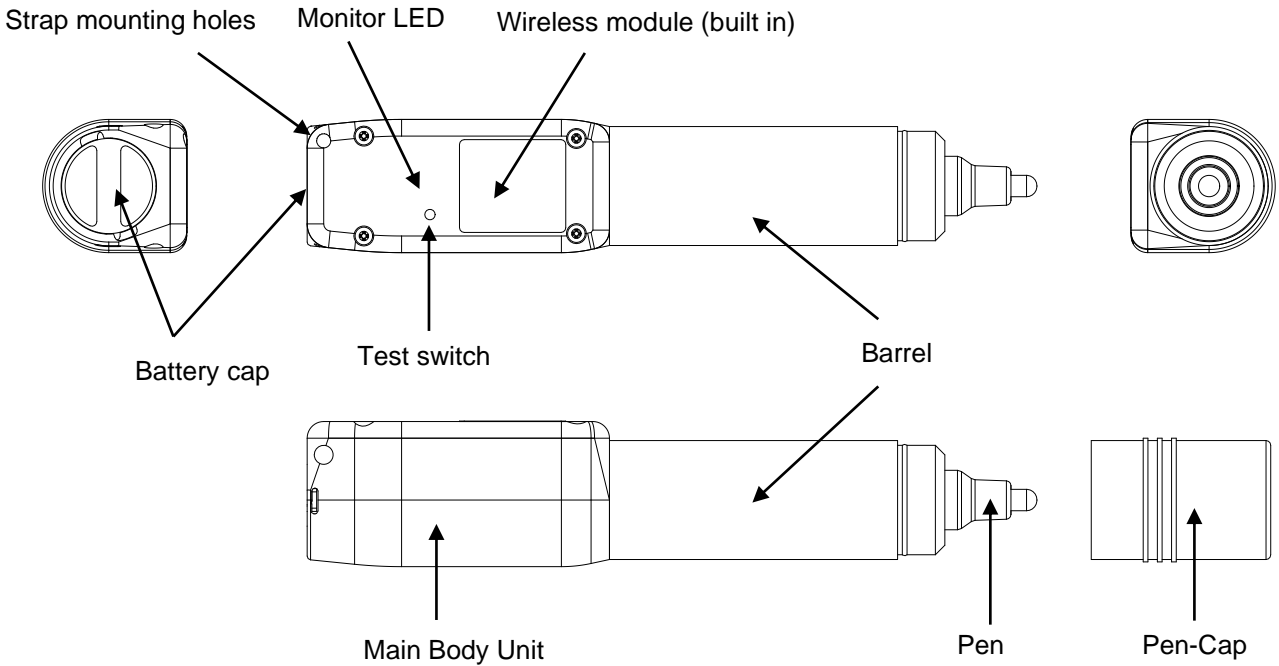

[Stamps]

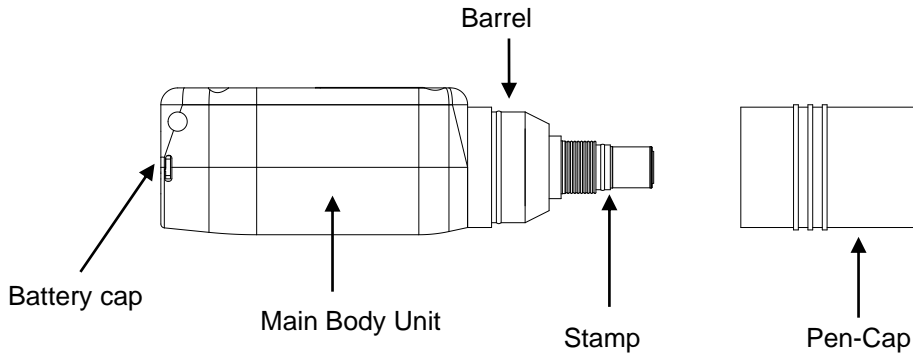

Wireless module (built in)	With "HRF-2402" pokayoke wireless module built in.
Barrel	Install a barrel compatible with the pen or stamp used. The Check Pen S can be used with various pens or stamps by changing the barrel.
Battery cap	Install a coin battery CR2032. The Check Pen S is delivered with a coin battery installed.
Pen-Cap	The pen-cap is common to the Check Pen S series.
Pen / Stamp	Commercially available pens and stamps are used. * Pens and stamps are not included.
Test switch	A switch for the remaining battery indication and communication test. It is also used as a pairing switch for pairing the Check Pen S with a receiver.
Monitor LED	An LED for communication confirmation /battery check. It lights up /blinks red/green according to the communication result.
Main Body Unit	A main part with a wireless module, coin battery, etc. installed.
Strap mounting holes	Please use it for attaching the optional strap. (Main body unit CP-SX only)

Check Pen S CP-##SX (When using the Main Body Unit CP-SXL)

[Pens]

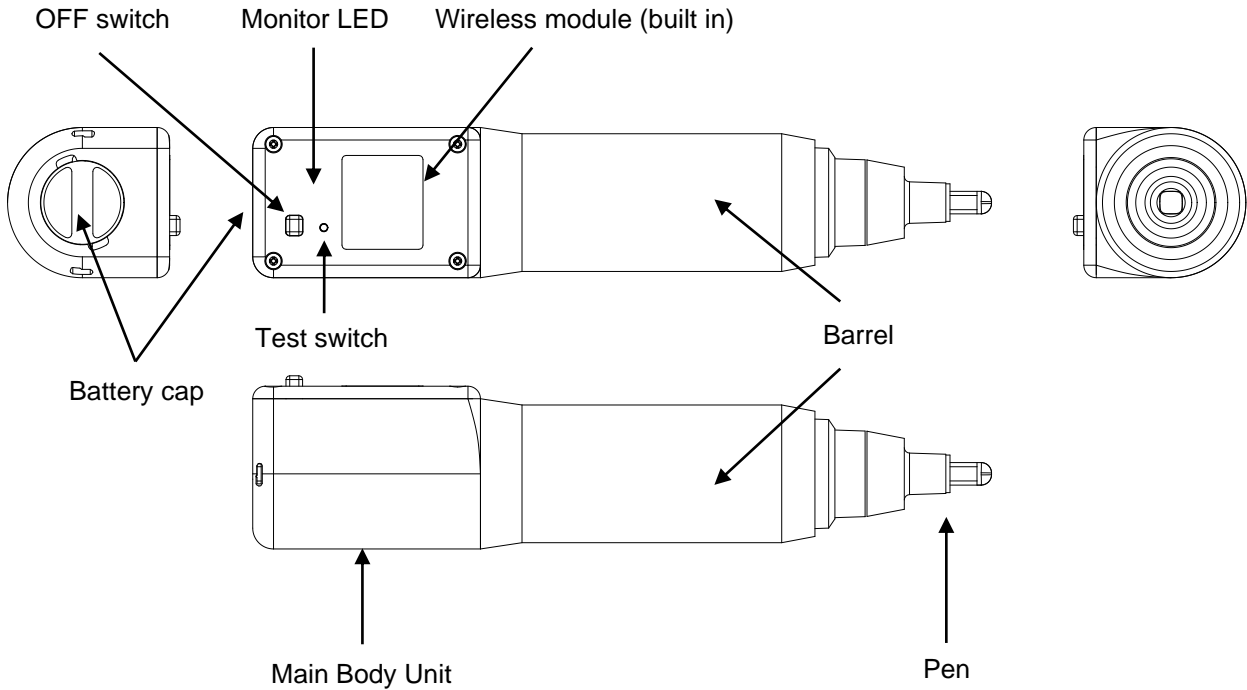

[Stamps]

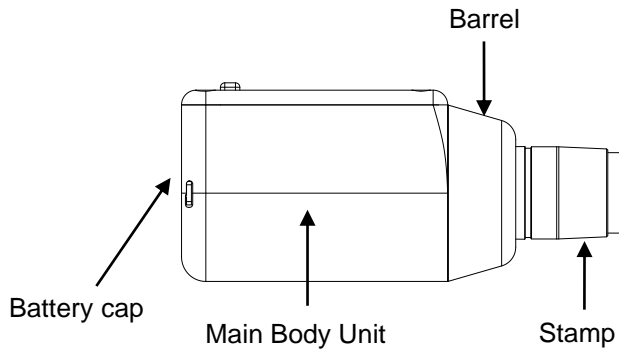

Wireless module (built in)	With "HRF-2402" pokayoke wireless module built in.
Barrel	Install a barrel compatible with the pen or stamp used. The Check Pen S can be used with various pens or stamps by changing the barrel.
Battery cap	Install a coin battery CR2032. The Check Pen S is delivered with a coin battery installed.
Pen-Cap	Use a genuine pen or stamp cap.
Pen / Stamp	Commercially available pens and stamps are used. * Pens and stamps are not included.
Test switch	A switch for the remaining battery indication and communication test. It is also used as a pairing switch for pairing the Check Pen S with a receiver.
OFF switch	This switch prevents accidental transmission. It is not be transmit while the switch is pressed. (Main body unit CP-SLX only)
Monitor LED	An LED for communication confirmation /battery check. It lights up /blinks red/green according to the communication result.
Main Body Unit	A main part with a wireless module, coin battery, etc. installed.

■How to Install

The installation method is explained in the main unit CP-SX, but you can also install in the same procedure for the main unit CP-SLX.

<How to install a pen>

Turn the barrel to remove it, and insert a pen. Turn the barrel to close it tightly.

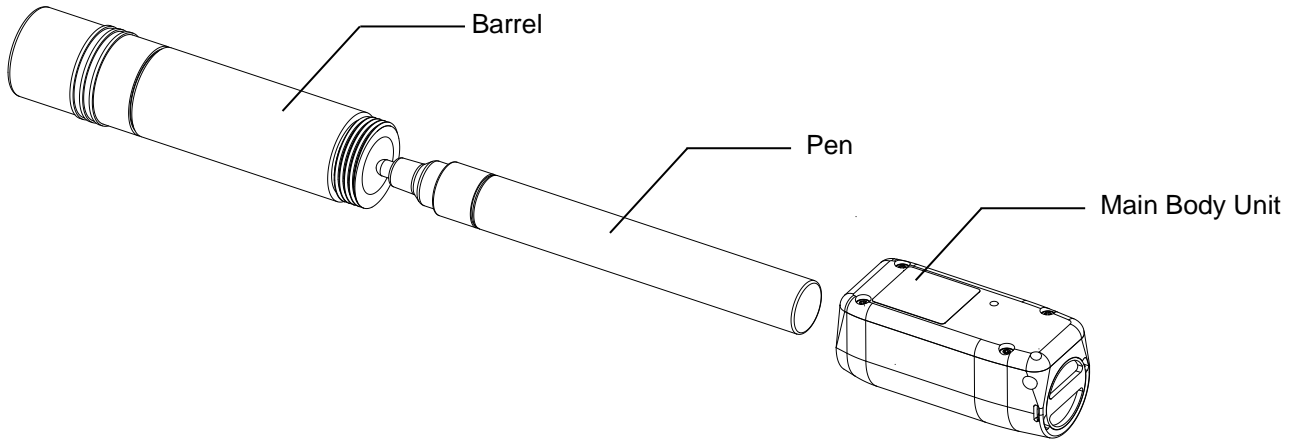

<How to install a stamp>

Turn the barrel to remove it, and insert a stamp into the stamp holder.

(Push in until the stamp does not rotate in the stamp holder.)

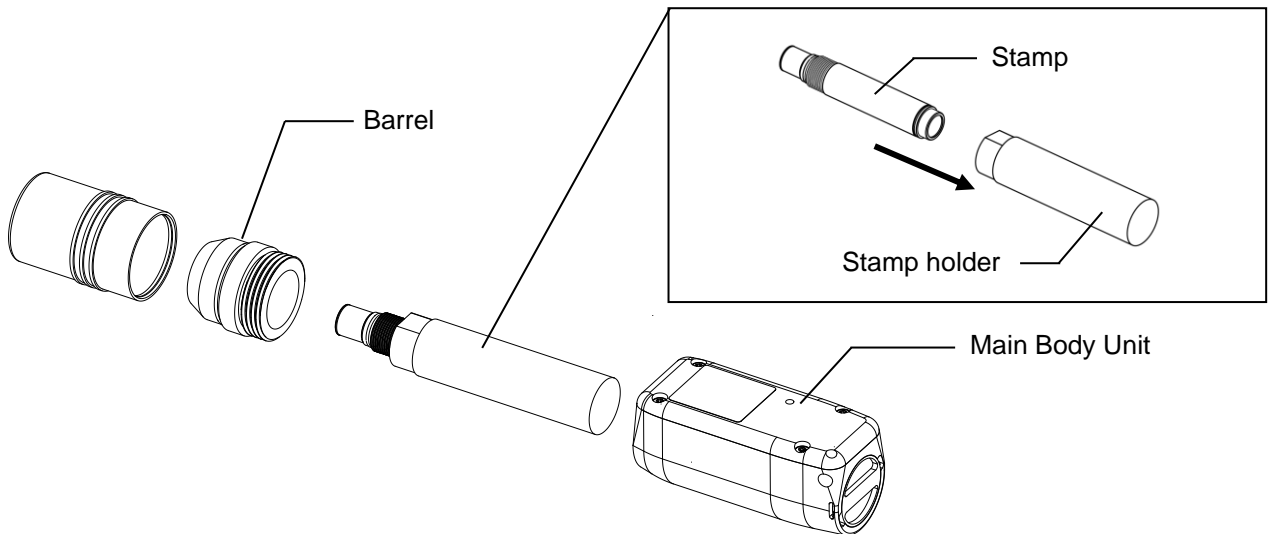

Insert a stamp into the barrel, and turn the barrel to close it tightly.

*Match the flat part (★) of the barrel and the stamp holder, when inserting a stamp into the barrel.

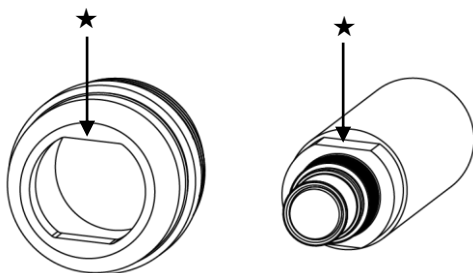

<How to install a spacer for skill writer (CP-70SX)>

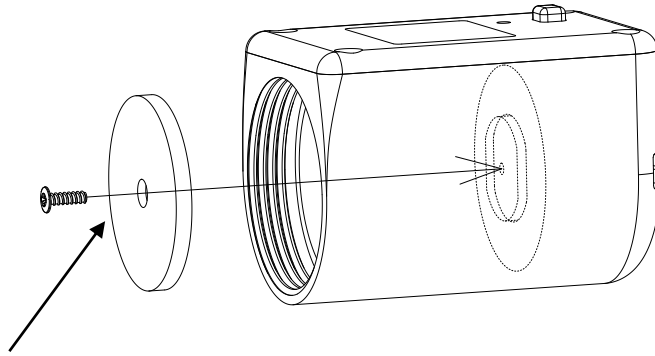

Be careful of the orientation of the spacer and overtightening of the screws.

<Installation/removal of battery>

Remove the battery cap by rotating it and install or remove the coin battery.

Close the battery cap tightly. Loose battery cap may cause a poor contact.

Be careful to install the coin battery in the correct direction (polarity).

The battery can be installed and removed in the same procedure for the main body unit CP-SLX.

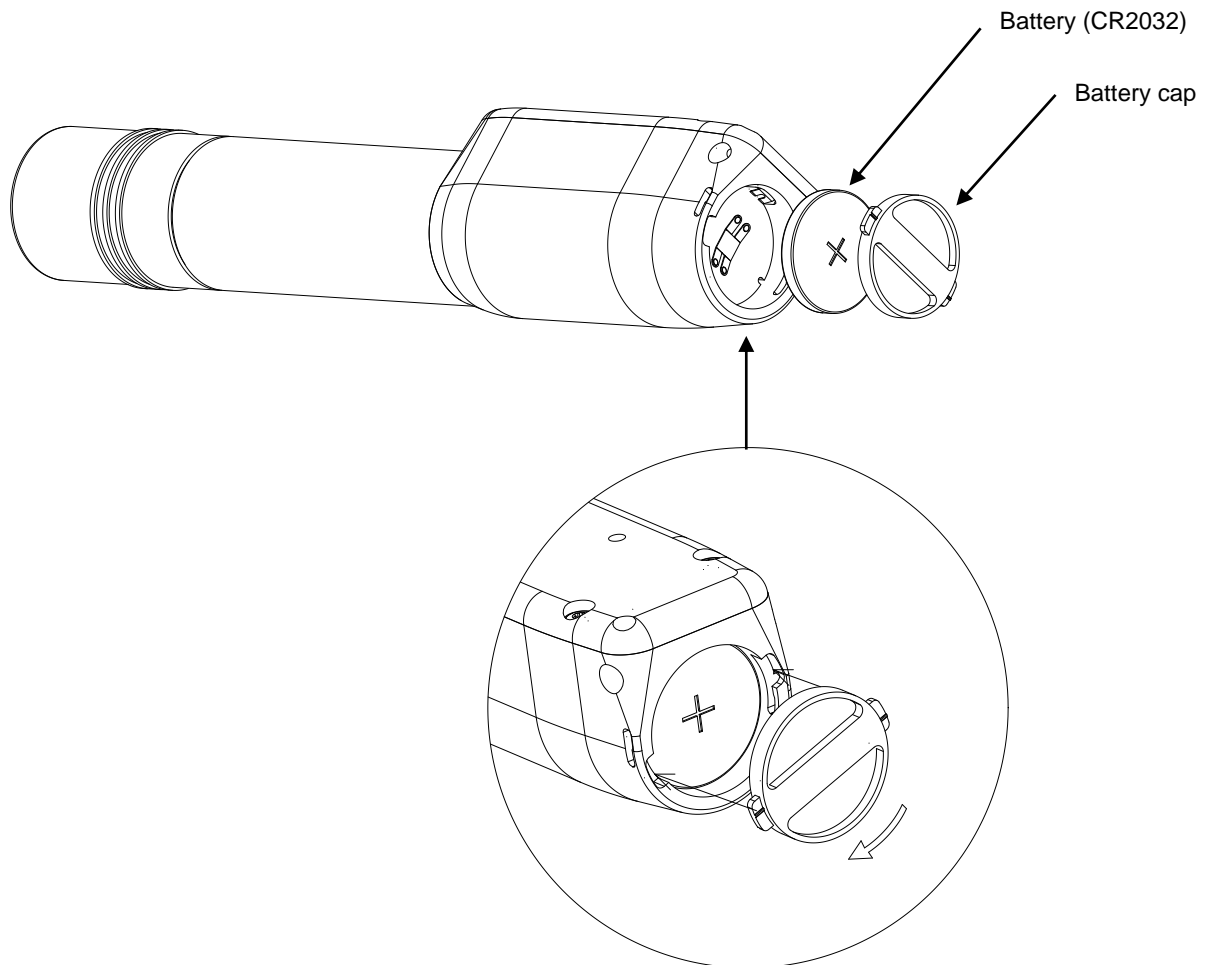

■Setting

The Check Pen S and a Pokayoke receiver TW-800R-*** need to be paired before use.

By pairing them, they recognize an identification signal from each other and communicate with each other.

This manual describes how to pair the Check Pen S with the receiver TW-800R.

For pairing with a receiver other than TW-800R, see the instruction manual of each receiver.

● Pairing (registration)

① **Press the lighting switch for paring** of the receiver, **and turn ON the power switch** at the same time.

The lighting switch for paring blinks and the receiver enters **the pairing mode for 10 seconds**.

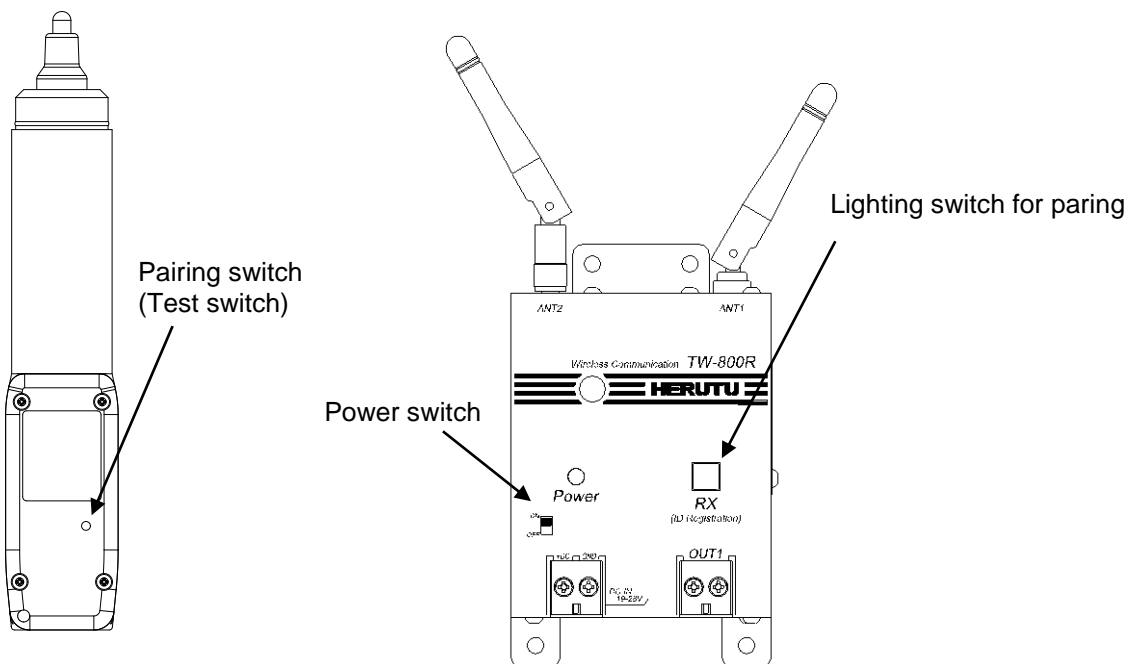

② Long press **the pairing switch** of the Check Pen S for **3 seconds or longer**.

③ **The lighting switch for paring of the receiver goes out** and pairing is complete.

When the lighting switch for paring stops blinking and lights up, this indicates that the pairing has failed. Turn OFF the receiver power and start the procedure again.

④ **Turn OFF the power** of the receiver once and **turn it ON again**, and the receiver can communicate with the paired Check Pen S .

● Reset pairing

① **Press the lighting switch for paring** of the receiver, and **turn ON the power switch** at the same time.

The lighting switch for paring blinks and the receiver enters **the pairing mode for 10 seconds**.

Long press the lighting switch for paring for **2 seconds or longer**, and the **lighting switch for paring lights up** and the paired (registered) data of the Check Pen S is deleted.

◆Notes

A long press on the pairing switch of the Check Pen S (3 seconds or more) when the receiver is not in the pairing mode resets the pairing with the receiver and prevents communication with the registered receiver. When pairing is reset by mistake, perform the pairing procedure again.

■How to Use the Check Pen S

① Turn ON the power switch of the receiver.

Make sure the receiving LED is OFF.

When the receiving LED lights up, the Check Pen S is not paired. Pair the receiver and Check Pen S.

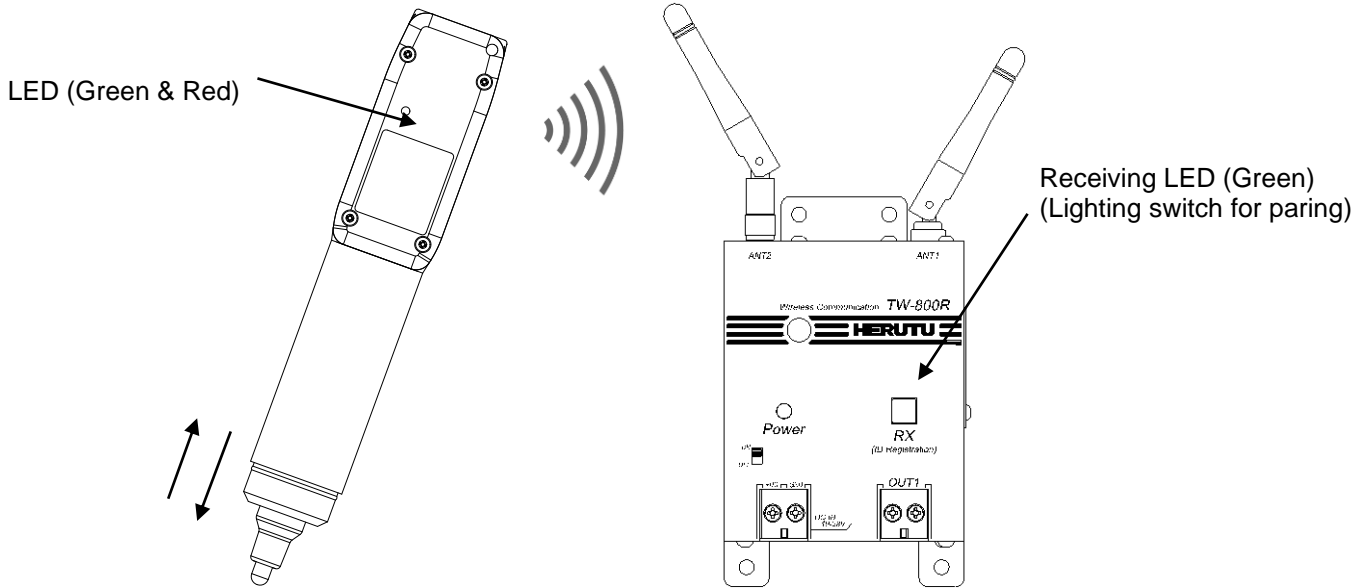

② Pressing the point of the Check Pen S with a certain force or more will generate a signal.

When the communication is executed normally, the receiver generates a relay output and the buzzer is activated according to the settings.

The green LED of the Check Pen S blinks once.

When the communication is not executed normally, the receiver is not activated.

The red LED of the Check Pen S blinks 10 times.

When the point of the Check Pen S is pressed, the built-in switch is pressed and a signal is generated.

No signal is generated by shaking the pen left and right instead of pressing it.

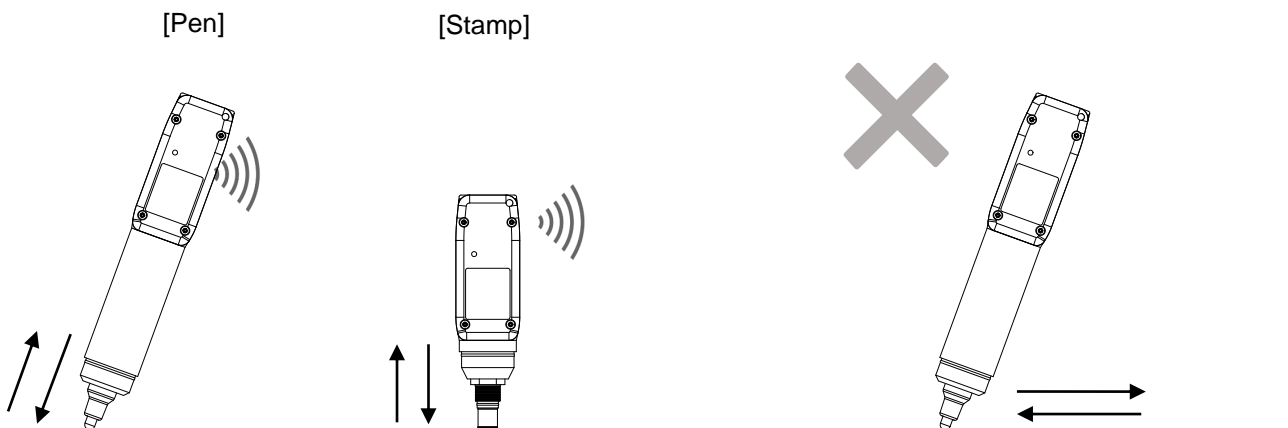

No signal is generated by not pressing the point of the pen, and even by shaking the pen left and right.

While the receiver is generating a relay output or preventing a double count, the receiver returns a BUSY signal to the Check Pen S. Upon receiving the BUSY signal, the green LED of the Check Pen S blinks 4 times.

	Check Pen S	Receiver
Communication OK	Green LED blinks 1 time	Receiving LED blinks 1 time.
Communication Failed	Red LED blinks 10 times	—
BUSY	Green LED blinks 4 times	—

The buzzer sounding time of the receiver is normally 100 msec. Only when the relay output time is set to 50 msec. and the double count prevention time is set to 10 msec., the buzzer sounding time is 50 msec.

*When an unpaired the Check Pen S transmits a signal, the red LED blinks 3 times.

●Test switch (pairing switch)

The Check Pen S is equipped with a test switch for communication and battery voltage checks. The Receiver LED is triggered by a signal from the test switch, but a relay output is not generated. When the test switch is pressed, the Check Pen S checks the battery remaining capacity. The result is indicated by the Check Pen S LED or the Receiver LED.

The test switch also can be used as a pairing switch. A long press on the test switch (3 seconds or more) resets the pairing with the receiver and prevents communication with the registered receiver. When pairing is reset by mistake, perform the pairing procedure again.

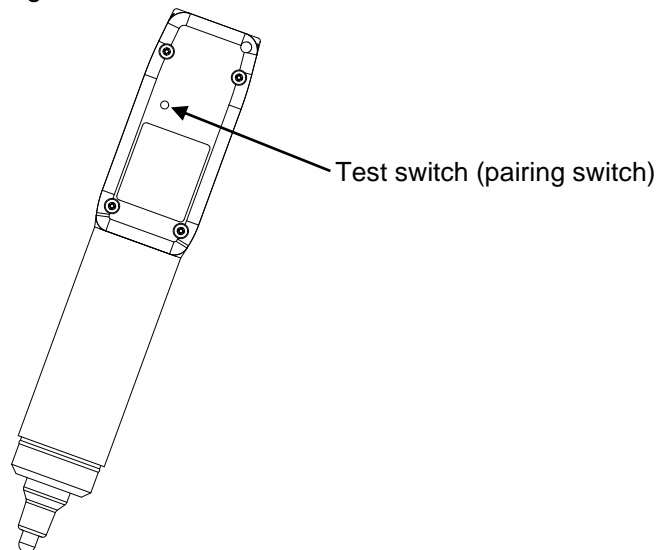

	Check Pen S	Receiver
Communication check	OK : Green LED blinks 1 time NG : Red LED blinks 10 times	Receiver(RX) LED blinks 1 time
Battery level low	Red LED: Lighting for 1 second	Receiver(RX) LED blinks 2 times

*After display of the communication check result (Communication OK/ NG), the Check Pen S indicates battery level low.

●Battery level notification function

The battery level notification function notifies the battery level status in two stages.

- ①Notification of low battery level with test switch: It is possible to check the battery level with the test switch.
When the battery is low, the red LED will light for 1 second.
- ②Battery replacement notice: If the battery level is lower than in ① and the battery needs to be replaced, the green LED flashing after transmission will change to an orange LED flashing.

When the orange LED blinks, please replace it with a new battery immediately.

When you replace the battery with a new one, the LED on the Check Pen S will return to green from the second and subsequent transmissions.

■Specifications

●Check Pen S

Item	Specifications
Compliance Standards	2.4GHz Low Power Data Communication System Radio Equipment of Certification Regulation Article 2, Paragraph 1 Item 19 Radio Equipment Regulations Article 20 of 49 Paragraph 1
Radio format	F1D
Frequency Band	2,403MHz-2,478MHz
Number of Channels	76CH
Modulation Method	GFSK
Communication Method	Simplex
Antenna Power	2.1mW
Input(s)	1 Test Switch
Display	Communication Status and Battery Level Notification (Red/Green)
Power Source	1 Coin Battery (CR2032)
Operating Environment	Temperature: 0-50 °C (32-122 ℉) Humidity: 80% or less (without condensation)
External Dimensions (W x H x D)	Refer to "Dimensions Drawing"
Weight	Refer to "Dimensions Drawing"
Antenna	PCB Antenna (The antenna is mounted on the built-in wireless module HRF-2402)
Battery Life	Approx. 300,000 uses (depending on usage conditions)

■ Dimensions Drawing

- Check Pen S

CP-02SX

CP-05SX

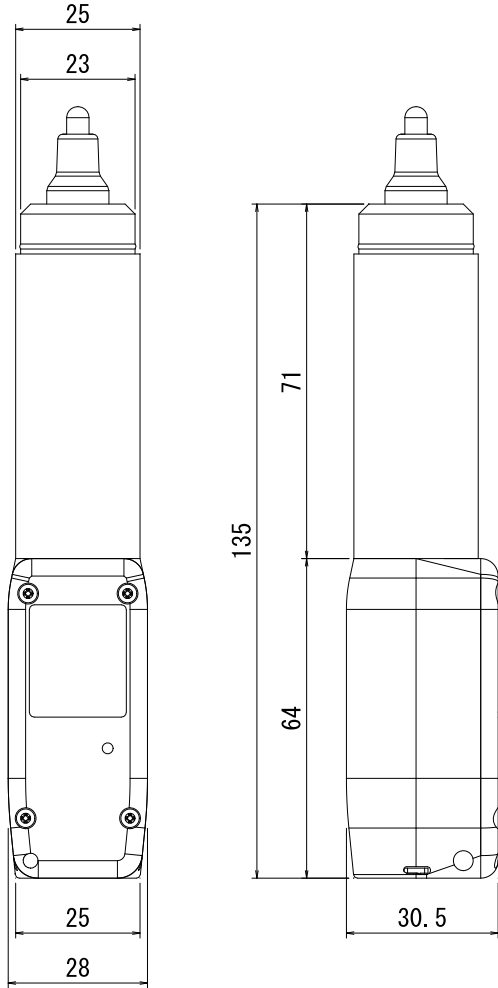

Weight* approx. 80g (2.8 oz) *Pen excluded

Use the commercially available pen cap.

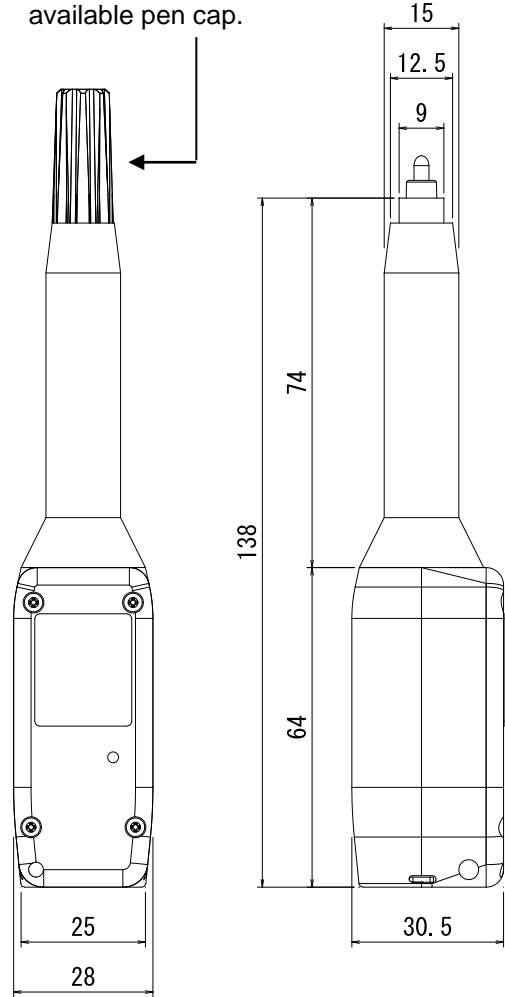

Weight* approx. 50g (1.8 oz) *Pen excluded

CP-09SX

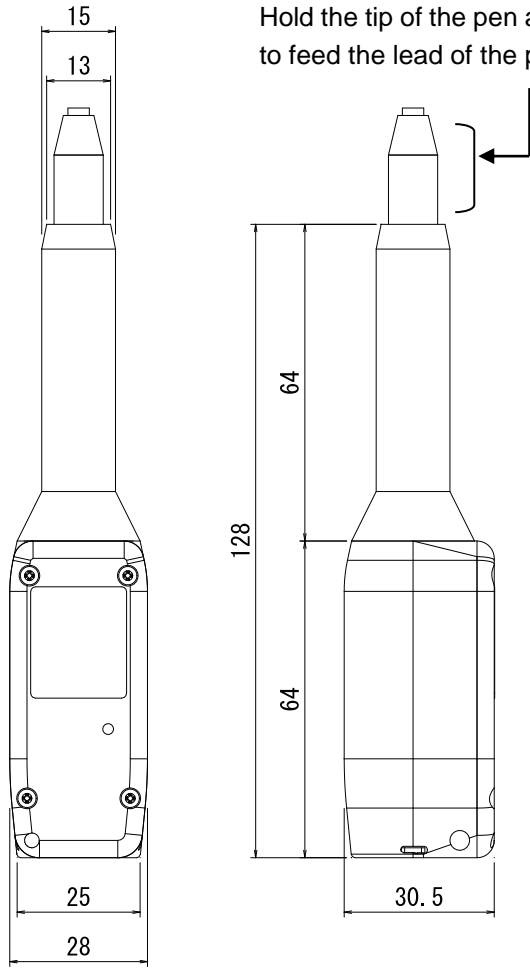

Weight* approx. 60g (2.1 oz) *Pen excluded

CP-11SX

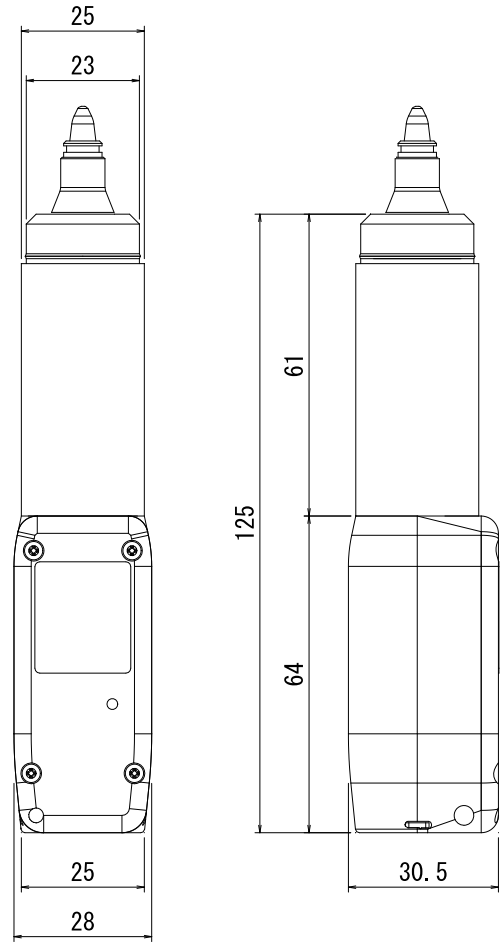

Weight* approx. 70g (2.5 oz) *Pen excluded

CP-26SX

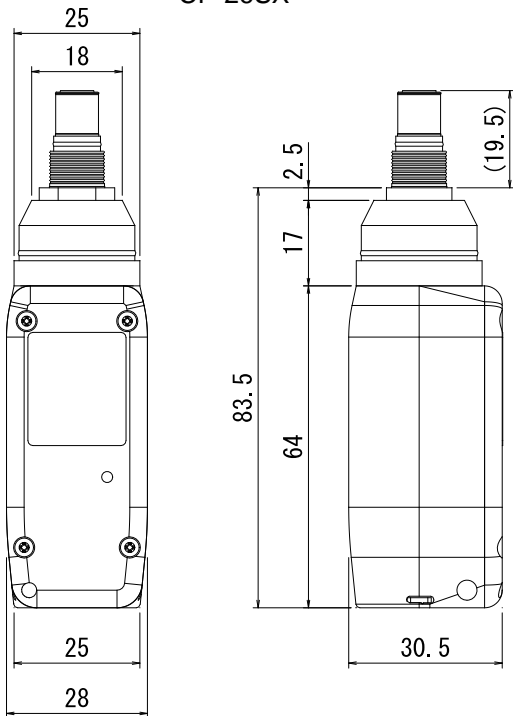

Weight* approx. 65g (2.3 oz) *Stamp excluded

Pen-Cap(Common) CP-S-CA

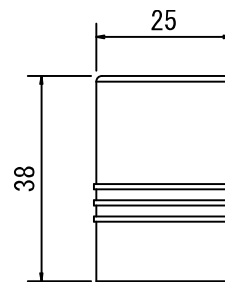

CP-70SX

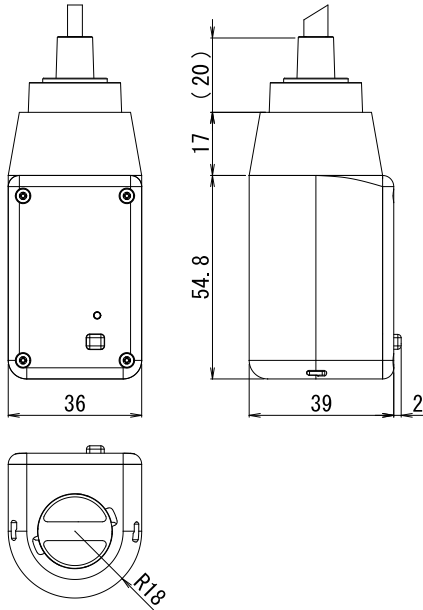

Weight* approx. 75g (2.7 oz) *Pen excluded

CP-71SX

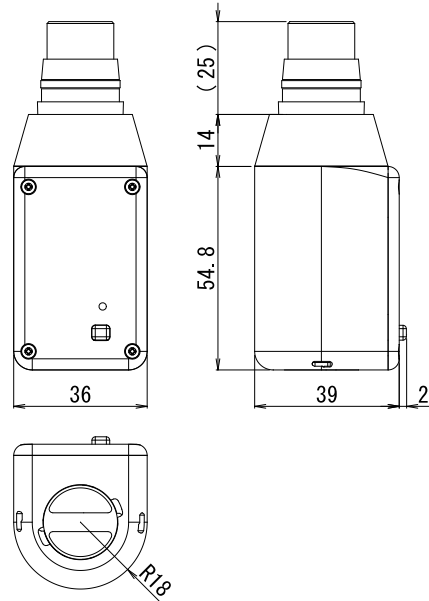

Weight* approx. 75g (2.7 oz) *Stamp excluded

CP-72SX

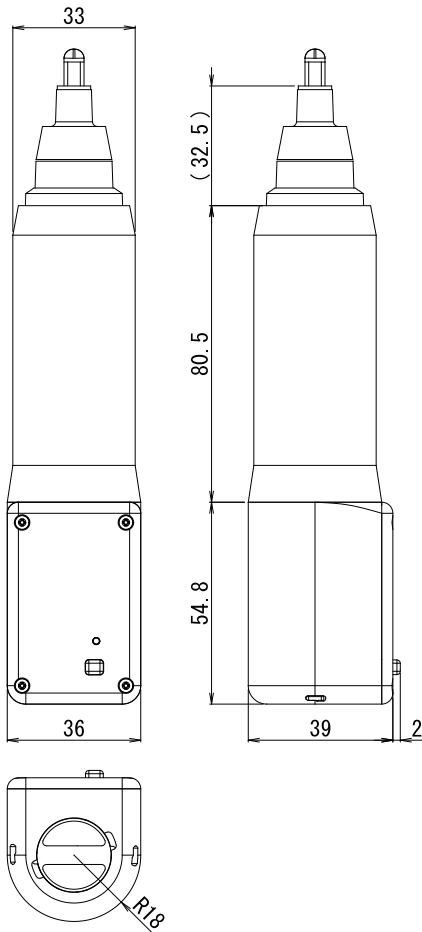

Weight* approx. 85g (3.0 oz) *Pen excluded

CP-81SX

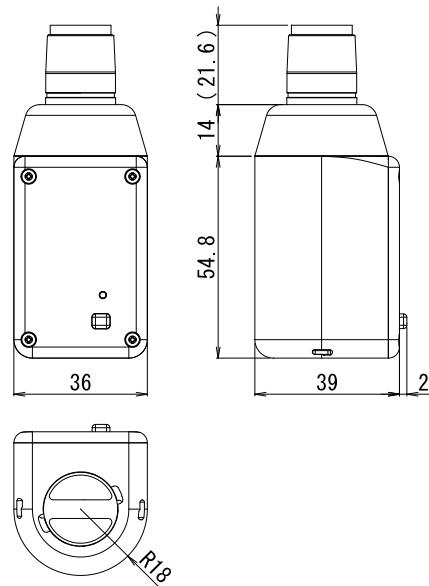

Weight* approx. 75g (2.7 oz) *Stamp excluded

■ Before Determining Fault

Phenomenon	Cause and remedy
The Check Pen S does not transmit LED (red or green) does not light up	Battery capacity is low.
	→Please replace the battery (CR2032) .
The red LED blinks 3 times after transmitting.	Pairing is not done. (not registered)
	→Perform pairing with the receiver to communicate with the Check Pen S. (See P.11)
The red LED blinks 10 times after transmitting.	The power of the receiver is not ON.
	→Make sure the power of the receiver to communicate with the Check Pen S is ON.
	The communication distance is too far.
	→The distance is beyond the maximum communication distance of the machine. Install the Check Pen S in a location where it can communicate with a receiver.
	The antenna installation status of the receiver is not good.
	→Check whether or not the receiver's antenna is surrounded by obstacles blocking radio waves or placed in the control panel (iron), and improve the installation status of the antenna. Also, consider using an external antenna.
The green LED blinks 3 times after transmitting.	Communication cannot be done due to external factors.
	→Use of a product using the same frequency band (2.4GHz band) as this product may prevent communication. Please contact our Sales Department with your product information.
Red LED lights up for 1 second after pressing the test switch.	The receiver is busy.
	→ The receiver is generating a relay output or preventing a double count. For the settings, refer to the instruction manual of the receiver.
Pairing cannot be done	Battery capacity is decreasing.
	→Please replace the battery (CR2032).
Pairing cannot be done	The receiver is not in the pairing mode.
	→Set the receiver to the pairing mode and press the pairing switch of the Check Pen S for 3 seconds or more. (See P.11)

■ After Service and Warranty

If something is wrong. If you should find anything wrong with the machine when using it under normal conditions, check the warranty and repair regulations and contact the outlet store through which you purchased the product or our Sales Office. The latest warranty and repair regulations can be found on our website.

The user is prohibited by law from disassembling or making modification to the unit or otherwise may be subject to punishment.

[Warranty Regulation]

This regulation (hereinafter referred to as the "Regulation") is for post-shipment warranty provided by HERUTU ELECTRONICS CORPORATION (hereinafter referred to as the "Company") so that you can use the Company's product you have purchased with confidence. The Regulation does not apply to special order products (custom products). In addition, purchased products shall be subject to the relevant manufacturer's warranty regulations, and the Regulation shall not apply.

Please note that in the event that the product you purchased comes with an instruction manual that describes the Company's old repair regulation, the latest Regulation will still apply.

1. Warranty period

Unless otherwise specified, the warranty period shall be "up to thirteen months from the date of shipment of the product by the Company". During the warranty period, the Company will replace the product with a new one or repair it free of charge in accordance with the provisions of the Regulation.

In addition, if a failure occurs during the warranty period due to the Company's responsibility and the product with the failure (hereinafter referred to as the "Product") is replaced with a new one or repaired free of charge, the warranty period of the Product will be "thirteen months from the date of initial shipment of the Product, or six months from the date of shipment of the Product that has been replaced or repaired, whichever comes later".

The warranty period for paid repairs shall be in accordance with the provisions of the Company's repair regulation.

2. Warranty scope

If a failure occurs during the warranty period due to the Company's responsibility, the Company will replace the product with a new one or repair it free of charge.

Even within the warranty period, the warranty does not apply in the following cases:

- A) In the event of failure or damage caused by improper handling by the customer, such as dropping or impact during transportation or movement by the customer
- B) In case of failure due to disassembly or modification of the main unit by the customer
- C) In case of natural disasters such as fires, earthquakes, floods, and in case of failure or damage due to abnormal voltage
- D) In case of failure caused by failure of equipment other than the Company's designated equipment connected to the Product
- E) In case of failure of the Product's accessories (AC adapter, antenna, connection cable, etc.)
- F) If damage is caused by the failure of consumables or limited-life parts included in the Product:

1. Consumables: Batteries (rechargeable, batteries, dry batteries, button batteries, etc.), recording media (SD cards, etc.)
2. Limited-life parts: Various switches (limit switches, push button switches, etc.) and various sensors
3. Other items that are worn out or have a service life due to use

If consumables or limited-life parts fail, we will replace or repair the parts for a fee.

- G) In case of failure caused by handling contrary to the usage and precautions described in the instruction manual of the Product
- H) If repaired, adjusted, or improved by elsewhere other than the Company
- I) If the Company is unable to reproduce the failure

3. About repair of the Product

Please note that repairing the Product requires equipment such as measuring instruments and tools, so the Company will handle it as a pick-up repair service at the Company.

4. About the shipping cost for replacement or repair of the Product

Shipping charges for sending the Product to the Company or a distributor, as well as shipping charges for sending the Product that has been replaced or repaired by the Company or the distributor to the customer, will be borne by the Company or the distributor.

5. Disclaimer

The Company is not responsible for any direct or indirect damages or monetary loss caused by failure of the Product or its use.

6. Additional notes

Please note in advance that the information of the Product described on the Company's website and in the catalogs, instruction manuals, technical materials, and other materials provided by the Company are subject to change without notice to customers.

[Repair Regulation]

This regulation (hereinafter referred to as the "Regulation") shall be applied to paid repair service (hereinafter referred to as the "Service") provided by HERUTU ELECTRONICS CORPORATION (hereinafter referred to as the "Company"). The Regulation does not apply to special order products (custom products). In addition, purchased products shall be subject to relevant manufacturer's repair regulations, and the Regulation shall not apply.

Please note that in the event that the product you purchased comes with an instruction manual that describes the Company's old repair regulation, the latest Regulation will still apply.

1. Subject of the Regulation

The Service is provided for the Company's products that are "beyond the scope of the warranty specified in the warranty regulation" and "from the sales start date to the end date of the repair period (seven years from the production end date)". However, please note that the end date of the repair implementation period may be earlier depending on the availability and procurement status of repair parts.

2. Establishment of contract

The contract shall be established when the customer approves the quotation presented by the Company and issues an order form before the end of the repair implementation period.

3. Purpose of the Service

The Company will provide the Service for the purpose of repairing the function and performance of the Company's product used by the customer if it fails beyond the scope of the warranty specified in the warranty regulation. Please note that the Service requires equipment such as measuring instruments and tools, so the Company will handle it as a pick-up repair service at the Company.

4. Usage fee for the Service

The usage fee for the Service shall be the total of the following fees:

A) Repair service fee

The repair service fee is the total amount of technical fees, parts costs, other expenses incurred, and applicable taxes associated with repairing the Company's product (hereinafter referred to as the "Product for repair") that the customer wishes to repair.

B) Shipping fee (including the cost of packaging boxes)

The Company kindly asks that customers bear the shipping costs for sending the Product for repair to the Company and for returning it from the Company. However, in the event that the Product for repair is sent by payment on delivery by the customer, the shipping cost will be included in the Service charge.

5. Warranty period and scope of the Product for repair

The warranty period for the Product for repair is "up to six months from the date of repair completion". However, please note that failures other than the repaired parts (repaired places or replaced parts) are not covered by the warranty of the Product for repair. In addition, if a failure occurs due to the Company's responsibility within the warranty period, the Company will again repair the product free of charge.

6. Handling of repair parts

A) In order to provide the Service stably for a long time and to promote environmental protection, etc., the Company may use recycled parts or alternative parts at the time of repair at its discretion.

B) The Company may, at its own discretion, collect the removed parts for the purpose of recycling or analysis at the time of parts replacement through the regulation of the Service. Please note that the collected parts are the property of the Company and will be recycled, used or discarded at its discretion.

7. Estimate for the Service

The estimate for the Service is basically free of charge. However, if the Company is unable to reproduce the failure, it will not be able to carry out repairs and will not provide an estimate. If a technical investigation is required to reproduce the failure, the Company will estimate the cost of reproducing the failure.

8. Return of unrepaired product

If the Company does not estimate the cost of the Service due to reasons such as being unable to reproduce the failure, it will return the Product for repair to the customer.

In addition, if the customer does not place an order within three months from the date of creation of the quotation, or if the customer does not accept the quotation and the customer expresses an intention not to carry out the repair, the Company will assume that the customer has canceled the request for the Service, and the Company will return the Product for repair to the customer without carrying out the repair.

In addition, if a shipping fee is incurred for returning the product, it will be borne by the customer.

9. Handling of personal information

The Company will properly handle personal information such as names and addresses being provided in accordance with the privacy policy posted on the Company's website.

10. Compensation for damages

- A) The responsibility of the Company for providing the Service shall be limited to the matters and contents specified in the repair regulation, and shall not include any damages incurred by the customer due to special circumstances (including loss of profits of the customer and damages based on claims for compensation made by third parties against the customer) and damages caused by the customer being unable to use the product due to a failure or defect of the Product for repair. However, this does not apply if the damage was caused by the Company's willful misconduct or gross negligence.
- B) Even if the Company is liable to the customer for damages in connection with the regulation of the Service, the Company's liability shall not exceed the amount equivalent to the value of the Product for repair, except in cases of willful misconduct or gross negligence on the part of the Company. The value of the Product for repair shall be calculated based on the residual value after depreciation or the price of products with equivalent performance sold in the market at the time of damage.

11. Additional notes

- A) The Company cannot restore stickers, LCD protective sheets, and coloring applied to the outer casing parts that you have attached yourself. In addition, if advertisement stickers were affixed at the time of sale, they cannot be newly prepared as repair parts when replacing the outer casing parts. After replacing the outer casing parts, the advertisement stickers will be returned without being affixed.
- B) Please note in advance that the information of the Product on the Company's website and in the catalogs, instruction manuals, technical materials, and other materials provided by the Company are subject to change without notice to customers.



HERUTU ELECTRONICS CORPORATION

422-1 Higashimikata-cho, Kita-ku, Hamamatsu, Shizuoka, 433-8104 Japan

(Sales dept) TEL.+81-53-438-3555 FAX. +81-53-438-3411

Website URL <https://www.herutu.co.jp/en/> E-mail info@herutu.co.jp